

**Instructions for V200, V210 V250
320 Ampere, 3 Pole Vacuum Motor
Controller Nonreversing or Reversing**



Fig. 1 V200 Motor Controller
(Type B Overload Relay shown)

THE CONTROLLER

The V200 motor controller, when wired as shown in Figure 6, will operate as a full voltage starter and will give protection against overload, but not against short circuit currents, when wired and provided with overload relay (OLR) heaters as listed in the heater selection table or when used with any means of inherent protection activated by motor temperature.

The controller should be protected against short circuits by providing branch circuit protection, in accordance with the National Electrical Code (NEC).

CONTROLLER RATINGS						
THREE-PHASE HORSEPOWER AT						
200V	230V	380V	460V	575V	800V*	1500V*
100	125	200	250	300	400	800

This industrial type control is designed to be installed, operated, and maintained by adequately trained workmen. These instructions do not cover all details, variations, or combinations of the equipment, its storage, delivery, installation, check-out, safe operation, or maintenance. Care must be exercised to comply with local, state and national regulations, as well as safety practices, for this class of equipment.

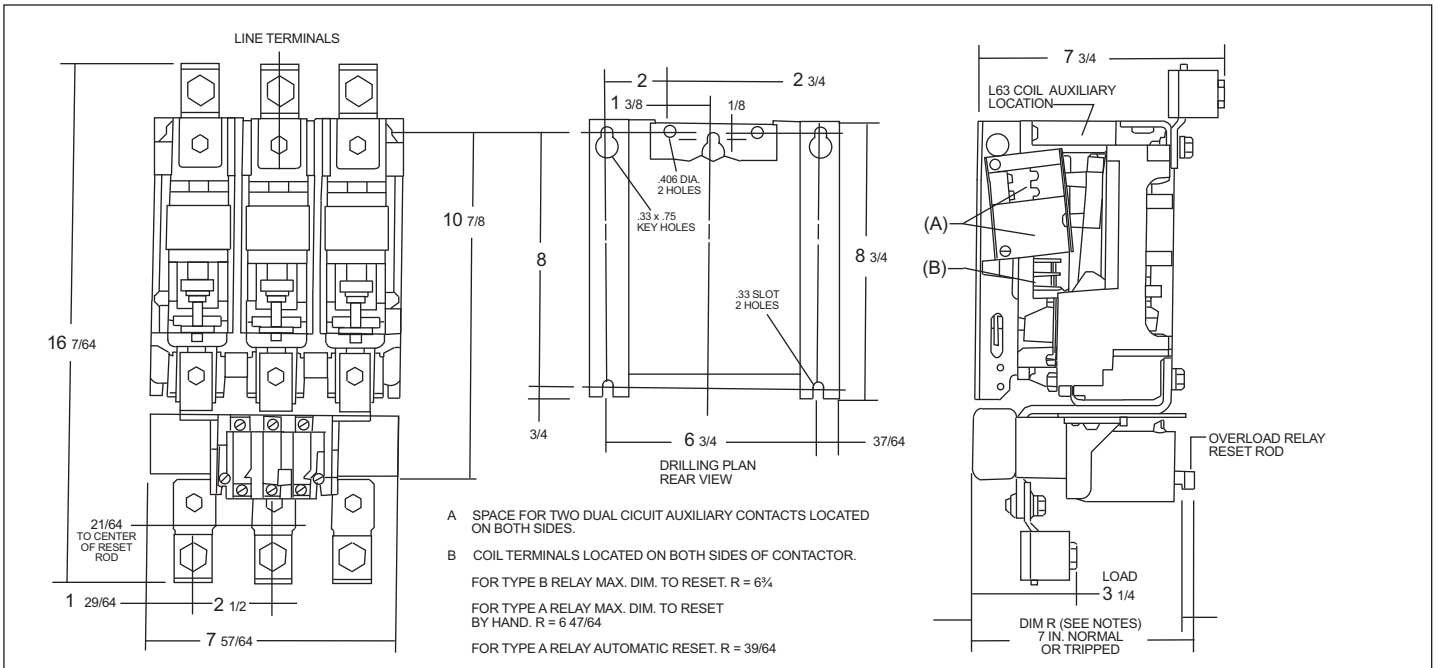

Fig. 2 Nonreversing Controller (V200) Dimension Drawing (Dimensions in inches)

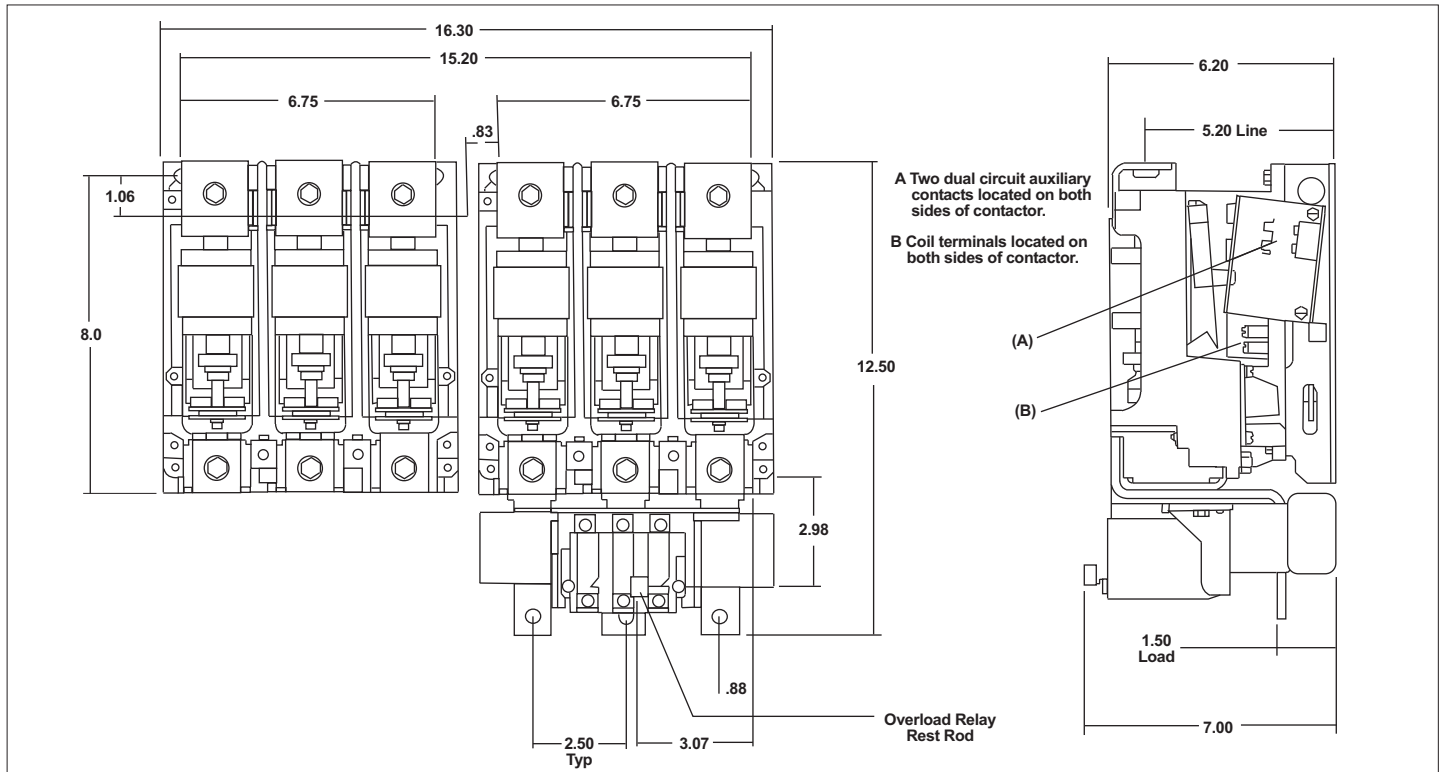

Fig. 3 Reversing Controller (V210) Dimension Drawing (Dimensions in inches)

MOUNTING

Mount each controller with four 5/16" x 18 or 1/4" x 20 bolts. Flat washers should be used on bolts entering slotted holes or keyholes. See Table VII.

TYPE B OVERLOAD RELAY (See Figure 1)

This V200 motor controller is usually equipped with a Type B block type ambient compensated overload relay (with gray reset rod). The controller can also be supplied with a non-ambient compensated overload relay (with red reset rod). This relay is a bimetal-actuated type equipped with a normally-closed control contact. An optional isolated normally-open control circuit is available for field mounting. When the overload relay trips, a yellow dot will appear flush with the molded surface below the reset rod. Resetting the relay returns this indicator to its normally concealed position.

TYPE A OVERLOAD RELAY (See Figure 4)

The V200 motor controller can be equipped with a Type A Block type non-ambient compensated overload relay (unmarked and with a red rest rod) or with a block type temperature compensated overload relay (marked "Ambient Compensated" and with a gray reset rod). The relay is of the bimetal actuated type equipped with trip

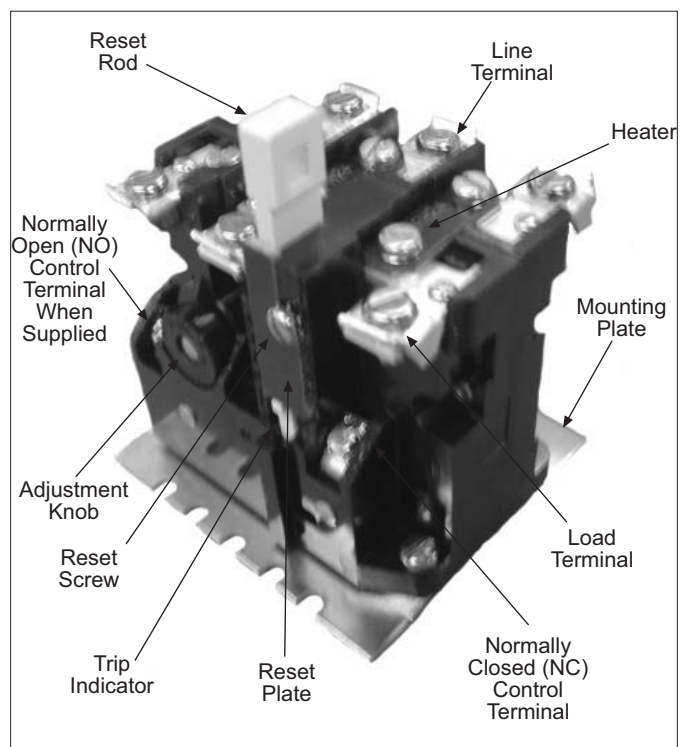

Fig. 4 Type A Block Overload Relay

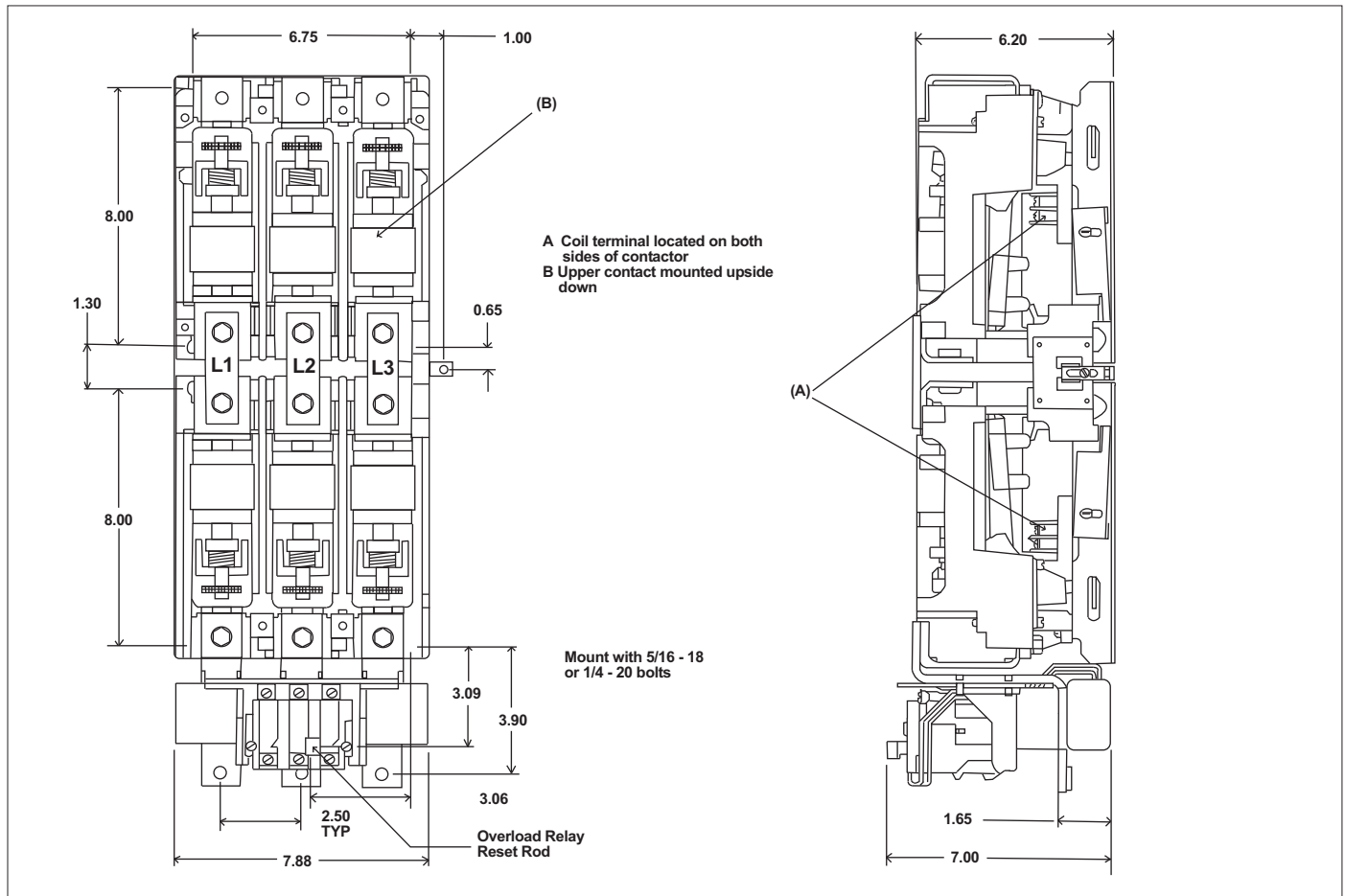

Fig. 5 Reversing Controller (V250) Dimension Drawing (Dimensions in inches)

indicator, trip adjustment covering $\pm 15\%$ of rating and a normally-closed control contact. It may be operated with either hand or automatic reset.

Reset operation is determined by the position of the plate on the load side of the overload base. Position the reset plate away from the panel to set the "hand" position. Loosen the locking screw, move the reset plate toward the panel, and retightens the screw to set the "auto" position.

Automatic reset should not be used with 2-wire control circuits where automatic starting of the motor may be hazardous.

OVERLOAD RELAY HEATERS

Overload relay (OLR) heaters are not included with

the motor controller and must be ordered separately per the heater selection table and the information listed below. When installing heaters be sure that connecting surfaces are clean and heaters are attached securely to the relay in the proper location with the screws provided. The trip rating of a heater in a 40°C ambient is 125% of the minimum full load current shown in Table 1. When tested at 600 percent of its trip rating, the relay will trip in 20 seconds or less.

Heaters should be selected on the basis of the actual full load current and service factor as shown on the motor nameplate or in the manufacturer's published literature. When the service factor of the motor is 1.15

OVERLOAD RELAY HEATERS (cont.)

to 1.25, select heaters from the heater application table. If the service factor of the motor is 1.0, or there is no service factor shown, or a maximum of 115% protection is desired, select one size smaller heater than indicated. When motor and overload relay are in different ambients and when using noncompensated overload relays, select heaters from the table using adjusted motor currents as follows: decrease rated motor current 1% for each °C motor ambient exceeds controller ambient. Increase rated motor current 1% for each °C controller ambient exceeds motor ambient.

TABLE I - HEATER SELECTION - A or B OLR			
Motor Full Load Current in Amperes for Use With 3 Heaters Only.			
Open Starter	Enclosed Starter		Heater
Compensated or Noncompensated OLR	Compensated OLR	Noncompensated OLR	Catalog (Code) Number
WITH 300/5 CURRENT TRANSFORMERS			
107-117	107-117	100-109	FH23
118-129	118-129	110-119	FH24
130-141	130-141	120-131	FH25
142-155	142-155	132-143	FH26
156-170	156-170	144-158	FH27
171-187	171-187	159-173	FH28
188-205	188-205	174-190	FH29
206-224	206-224	191-208	FH30
225-244	225-244	209-227	FH31
245-263	245-263	228-247	FH32
264-292	264-292	248-273	FH33
293-318	293-318	274-300	FH34
319-350	319-320	301-320	FH35

WARNING: To provide continued protection against fire and shock hazard, the complete overload relay must be replaced if burnout of a current element occurs. See Table III.

TABLE III - OVERLOAD RELAY CONTROL CONTACT RATINGS				
AC Volts	Normally Closed		Normally Open	
	Make	Break	Make	Break
Type A 24 - 120 120 - 600	20A 2400VA	2A 240VA	5A 600VA	.5A 60VA
Type B 24 - 120 120 - 600	30A 3600VA	3A 360VA	30A 3600VA	3A 360VA

TABLE III - REPLACEMENT OVERLOAD RELAY	
OVERLOAD RELAY	CATALOG NUMBER
Type B Non-ambient compensated	BN13JP
Type B Ambient compensated	BA13JP
Type A Non-ambient compensated	AN13P
Type A Ambient compensated	AA13P

TYPE GCO CURRENT TRANSFORMERS

The Type GCO current transformers were specially designed to mount on A200 and V200 controllers and operate the Types A or B thermal overload relays.

The 600 volt 300/5 ratio Type GCO transformers are identified by their bell shape, black case, and molded nameplate. Their single turn primary winding is provided by the controller load connection straps. The secondary wires - one white, the other black - are color coded for polarity identification.

The 1500 volt 300/5 ratio Type GCO transformers are identified by their doughnut shape, black case and red nameplate. Their primary and secondary windings are the same as the 600 volt version. Only their insulation voltage is different.

These Type GCO current transformers are **not** to be used to power additional auxiliary devices and should never be energized with the secondary leads open circuited since the open circuit overvoltage can damage the transformer.

The combination of the Type GCO 300/5 Ratio Current Transformer, Type A or B thermal overload relay, and V200 controller is intended to provide motor overload protection for motors with full load amperes (FLA) from 107 to 320 amps up to the maximum voltage shown on the controller nameplate.

COIL

The operating coil has a "figure-eight" shape and is really two coils in series, with a connection to their common point. Both coils are encapsulated in one environment-immune coil shell, which also contains a full-wave bridge. When AC is connected directly to terminals A and B on the coil shell, the magnet excitation is unfiltered DC. The magnet will not chatter as AC magnets sometimes do, but at less than rated volts it may hum slightly. A normally-closed Type L63 auxiliary contact, set to open slightly before the armature fully closes, is connected to terminals C and D on the coil shell. When adjusted correctly, this contact allows a relatively high current through the pickup winding, and as the controller closes, the contact inserts the holding winding, which reduces the coil current to a low value sufficient to hold the magnet closed without overheating. No external resistors are required.

COIL DATA (TYPICAL VALUES)					
Coil Voltage	Freq.	Inrush VA	Sealed VA	Sealed Watts	Part Number
110-120	Any	600	26	26	7874A09G01
220-240	Any	600	26	26	7874A09G04
440-480	Any	600	26	26	7874A09G05
550-600	Any	600	26	26	7874A09G06
24	DC	-	-	26	7874A09G07
48	DC	-	-	26	7874A09G08

MAGNET OPERATING RANGE

When properly adjusted as described in previous sections, the controller should operate within the ranges shown in Table IV.

TABLE IV - OPERATING RANGES				
Rated Coil Voltage	Pick-Up-To-Seal Voltage		Drop-Out-To-Full Open Voltage	
	Above	Below	Above	Below
110-120 VAC	60	77	10	50
220-240 VAC	120	152	20	100
440-480 VAC	240	304	40	200
550-600 VAC	300	385	50	250
24 VDC	12	15	2	10
48 VDC	24	30	4	20

If the magnet chatters, look for mechanical interference that prevents the magnet from sealing. If there is no interference, then the magnet itself may be misaligned. The magnet gap can be seen from the left and right side with the help of a flashlight. A screwdriver inserted into one of the long slots (Y-Figure 9) can be used as a lever to put a corrective set into the mounting plate around the magnet. It should not be necessary to do this unless the contactor has been damaged and it can be seen that the armature does not fit against the magnet. A poor magnet-to-armature fit usually produces a high dropout voltage and/or the chatter.

Mechanical interference can be produced by various incorrect adjustments. Two specific points to check are:

- A. Armature travel incorrect, causing the contact springs to be compressed into a solid, non-resilient "tube" that stops the crossbar rigidly. Refer to Eaton Service for assistance.
- B. The auxiliary contact mounting brackets are mis-adjusted, so that a contact plunger bottoms solidly before the magnet seals. When the contactor is

fully sealed closed, there should still be a small amount of travel remaining for the plungers. See **Auxiliary Contact Adjustment.**

SHORT-CIRCUIT RATINGS

This motor controller is suitable for use on a circuit capable of delivering not more than the current (rms symmetrical amperes) shown below in circuits rated not more than the voltage shown below:

TABLE V - SHORT-CIRCUIT PROTECTION					
Short-Circuit Protective Device (SCPD)	Max. size SCPD	Current Breaker Interrupting Rating	Short-Circuit Rating		Typical Disconnect Device Cat No. Prefix
			Current	Voltage	
Class J Fuse	600A	-	65,000A	600V	MCS (High Mag. Trip)
			100,000A	480V	
Class K Fuse	600A	-	65,000A	600V	MCS (High Mag. Trip)
			100,000A	480V	
Class L Fuse	600A	-	22,000A	600V	MCS (High Mag. Trip)
Class R Fuse	600A	-	65,000A	600V	MCS (High Mag. Trip)
			100,000A	480V	
Class T Fuse	600A	-	65,000A	600V	MCS (High Mag. Trip)
			100,000A	480V	
Magnetic Only ¹ Type CB ²	400A	Marked HMCP	35,000A	600V	HMCP
Thermal/Mag ³ Type CB ²	600A	25,000A 30,000A 35,000A	25,000A	600V	HLA, HLB, HLC
			30,000A	480V	LA, LB, LC
			42,000A	1000V	HLA, HLB, HLC
ThermalMag ³ Type CB ²	600A	14,000A 22,000A	14,000A	1000V	HNAM
			22,000A	1000V	HPBN
	800A	14,000A 22,000A	14,000A	1000V	HNAM
			22,000A	1000V	HPBM

¹ Instance Adjustment Trip
² Circuit Breaker
³ Inverse Time

TABLE VI - POWER CIRCUIT TERMINALS	
Location	Wire Size
Overload Relay	# 14
Line and Load	# 0 - 500 MCM
Wire with copper conductors only sized on 75°C conductor ampacity. See Table VII for torque values.	

AUXILIARY CONTACTS - TYPE J

Two mounting brackets for auxiliary contacts are provided for each contactor. Auxiliary contacts themselves must be ordered separately. An auxiliary contact with one or more normally-open poles may be used as the holding circuit auxiliary. A maximum of four auxiliary units can be installed in the brackets for each non-reversing contactor (three in each reversing contactor). They mount by means of a spring clip and retainer screw. To remove the unit rotate the retainer screw several times (counterclockwise) and then slide the auxiliary contact unit out of the recess.

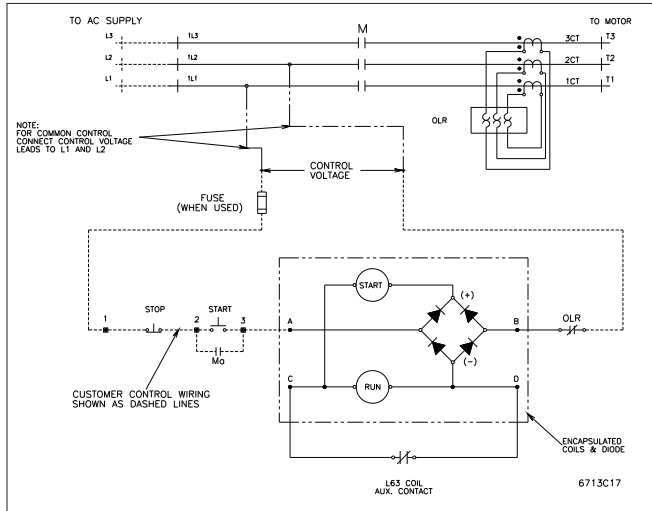

Fig. 6 Nonreversing Control Circuit

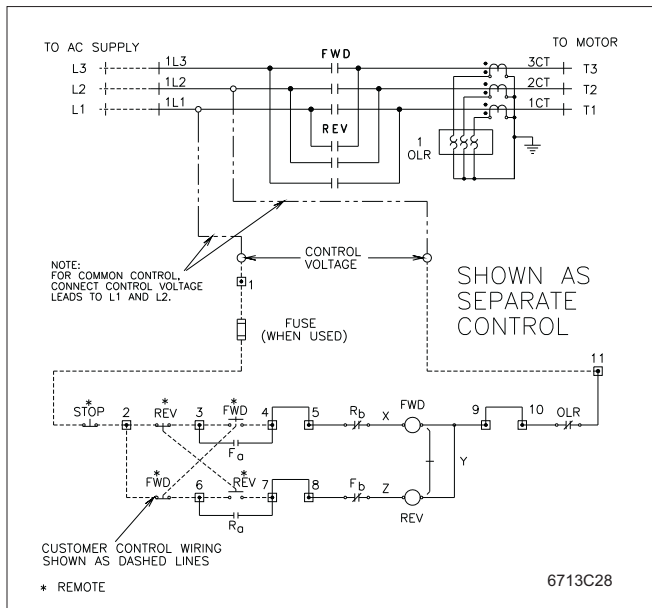

Fig. 7 Reversing Control Circuit

TYPE J AUXILIARY CONTACTS			
Contact Type		Catalog No.	
2	Normally Closed	J02	
2	Normally Open	J20	
1	Normally Open and 1 Normally Closed	J11	
1	Normally Open and 1 Normally Closed, Closed, Delayed Breaker	J1C	
TYPE J CONTACT RATINGS (A600, R300)			
Voltage	Continuous	Make	Break
120-600 VAC	10A	7200VA	720VA
72-120 VAC	10A	60A	720VA
28-72 VAC	10A	60A	10A
28-300 VAC	1.0A	28VA	28VA

MECHANICAL INTERLOCKS

Mechanical interlocks are used when a pair of contactors must be mechanically protected against the closing of one when the other is already closed. For the horizontal configuration, the Type M33-5 is used. For the vertical configuration, the M36-2 is used. Both mechanical interlocks occupy one recess in each contactor.

GENERAL

The contactor portion of a V200 controller (see Figure 9) has its main contacts sealed inside ceramic tubes from which all air has been evacuated, i.e., the contacts are in a vacuum. No arcboxes are required, because any arc formed between opening contacts in a vacuum has no ionized air to sustain it. The arc simply stops when the current goes through zero as it alternates at line frequency. The arc usually does not survive beyond the first half cycle after the contacts begin to separate. The ceramic tube with the moving and stationary contacts enclosed is called a **vacuum interrupter** or a **bottle**, and there is one such bottle for each pole of the contactor. A three-pole contactor has three vacuum bottles. A metal bellows (like a small, circular accordion) allows the moving contact to be closed and pulled open from the outside without letting air into the vacuum chamber of the bottle. Both the bellows and the metal-to-ceramic seals of modern bottles have been improved to the point that loss of vacuum is no longer cause for undue concern.

The moving contacts are driven by a molded plastic crossbar supported by two pre-lubricated ball bearings that are clamped in alignment for long life and free motion.

The contacts in an unmounted bottle (vacuum interrupter) are normally-closed, because the outside air pressure pushes against the flexible bellows. For contactor duty, the contact must be "normally-open" when the operating magnet is not energized. Therefore, the contacts of the vacuum bottles must be held apart mechanically against the air pressure when used in a contactor. In the contactor, all of the bottles are held

open by a single kickout spring in the rear of the contactor. The kickout spring pulls against the moving armature and crossbar and thereby forces the bottles into the open position. In the open position, the crossbar is pulling the moving contacts to hold them open.

The controller is intended to be mounted with its mounting plate vertical and the moving stem of the vacuum bottles aimed down. However, mounting position is not critical. If an unusual position is required, it is wise to check the pickup voltage on a bench before installation, with the controller oriented as it will ultimately be installed. The kickout spring can be adjusted as described under **Kickout Spring Adjustment**, if required to obtain the correct pickup voltage.

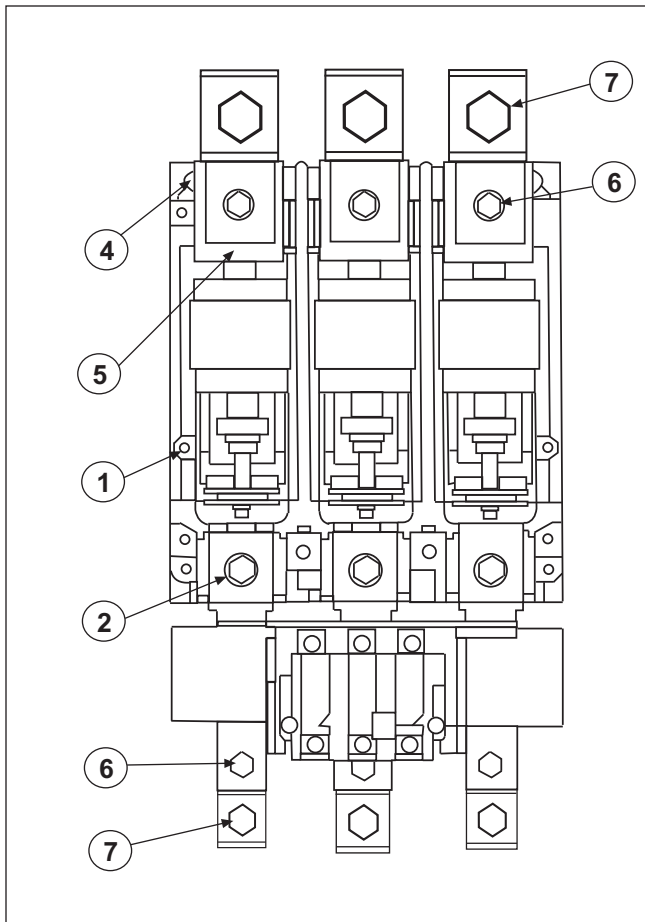

Fig. 8 Torquing Locations

CONTACT FORCE AND ALTITUDE

A Vacuum motor controller is affected by atmospheric pressure on the bellows of the vacuum bottle. Up to an altitude of 3300 feet, the contactor is designed to tolerate normal variations in barometric pressure. If the contactor is to be operated over 3300 feet above sea level, consult the factory.

CONTACT WEAR ALLOWANCE

Contact material vaporizes from the contact faces during every interruption and condenses inside the bottle. This is normal, and is provided for by **overtravel**, or wear allowance. When the contactor is fully closed, there is a gap between the pivot plate and the bottle nuts. See Figure 9. As the contacts wear, this gap decreases. When any gap goes **below .020 in.**, the unit should be replaced. Use the .020 in. Thick fork-shaped overtravel gauge supplied for this measurement. Part No. 7874A59H01.

CAUTION: The easiest way to close the contactor is to energize the coil. If the coil is energized for this or other maintenance, use adequate care to guard against electrical shock.

Do not re-adjust the bottle nuts to reset overtravel as the bottles wear. Once placed in service, overtravel should be checked but not adjusted. A star-wheel lock is included for locking the bottle nuts of each bottle to prevent tampering.

CHECK-OUT, VACUUM INTERRUPTERS

The dielectric strength of the interrupters should be checked before the contactor is energized for the first time and regularly thereafter to detect any deterioration in the dielectric strength of the contact gap. A good interrupter will withstand a 5.5KV, 50 or 60 hertz test voltage for one minute across a 0.090 inch contact gap, which is the normal new gap.

When the vacuum bottle is tested with voltage over 5000 volts across its open gap, there is some possibility of generating X-rays. Test time should be minimized and personnel should not be closer than 10 feet. This is a precaution until such time as the possible hazard is better understood and standards are published.

Periodic dielectric tests across open contacts are desirable since under certain operating conditions the contactor may perform satisfactorily even though one

TABLE VII - RECOMMENDED DRIVING TORQUE

Location (Qty.)	Driving Torque (lb-in.)	Fig. 8 Item Refer.	Fig. 9 Item Refer.	Location (Qty.)	Driving Torque (lb-in.)	Fig. 8 Item Refer.	Fig. 9 Item Refer.
Coil Terminals (4)	7-9	1	-	Coil Mounting Screws (2)	10-15	5	M
OLR Bus Connections (6)	220	2	-	Lug Bolts (6)	300-400	6	-
Base Mounting Screws (4)	60-65	4	S	Pressure Wire Connectors (6)	300-400	7	-

vacuum interrupter becomes defective. Dielectric tests should be made with the contactor in the same position it has when operating.

The interval between periodic tests depends on the number of operations per day, environmental factors, and experience. It is a matter of operator judgment, and philosophy of preventative maintenance.

CHECK-OUT, MECHANICAL

Make sure all power circuits are de-energized and isolated. The controller can be checked in its cabinet or outside.

If the controller is checked in its cabinet, make certain that the contactor coil is electrically isolated, to prevent feedback into a control transformer that could be hazardous.

Connect a separate power source of correct AC voltage to the coil of the contactor. Operate appropriate pushbuttons to close and open the contactor. If the contactor does not close fully or does not drop out fully refer to **Magnet Operating Range**.

While the contactor is closed, observe the overtravel gap between the pivot plates on the crossbar and the bottle nut on each pole. This overtravel gap should be not less than .045 inch when the contactor is new. If less refer to **Contact Wear Allowance**. Disconnect separate power source before proceeding.

While the contactor is open, attempt to pull the armature forward. The armature should not move because it should already be firmly against the plastic main frame. If it does move refer to **Kickout Spring Adjustment**.

CHECK-OUT, INSULATION LEVEL

After installation, and before energizing the controller for the first time, measure and record the insulation resistance between poles and from each pole to ground. It is not practical to specify an absolute value for this reading since it is dependent on other connected apparatus, and conditions of service. However, any unusually low reading or sudden reduction in this reading after the contactor has been in service indicates a possible source of trouble, and the cause should be determined and corrected before restoring power.

MAINTENANCE

Establish a maintenance program as soon as the controller is installed and put into operation. After the controller has been inspected a number of times at monthly intervals, and the condition noted, the frequency of inspections can be increased or decreased to suit the conditions found, depending upon the severity of the controller duty. It is a matter of operator judgment.

This industrial type control is designed to be installed, operated, and maintained by adequately trained work-

men. These instructions do not cover all details, variations, or combinations of the equipment, its storage, delivery, installation, check-out, safe operation, or maintenance. Care must be exercised to comply with local, state, and national regulations, as well as safety practices, for this class of equipment.

All work on this controller should be done with the main circuit disconnect device open. Also, disconnect power from any other external circuits. Discharge any hazardous capacitors.

LOSS OF VACUUM

Gross loss of vacuum is highly unlikely, but it can be checked easily. With the contactor open, pull downward on the bottle nuts, one pole at a time, using an effort of about 20 pounds. If the bottle nuts (see Figure 9) move easily away from their pivot, the vacuum has probably failed and the bottle must be replaced.

It is also unlikely, but possible, to have a very slight leak that does not change the bottle force appreciably, but which might seriously damage the ability of the bottle to interrupt. In this regard, it must be remembered that in a three-phase ungrounded circuit, it is possible for any two good interrupters to successfully interrupt the circuit even if the third interrupter is weak. But this condition should not be allowed to continue. It can be detected only by an electrical test. See **Check-out Vacuum Interrupters**.

WARNING: All work on this contactor should be done with the main disconnect device open. As with any contactor, there is danger of electrocution and/or severe burns. Make certain that the power is off.

Changing the Operating Coil

The operating coil has a pickup winding which is intermittently rated. It may burn out in only minutes if continuously energized at the rated voltage because the L63 auxiliary contact does not open correctly.

Each AC coil contains its own rectifier to convert the applied AC into unfiltered full-wave rectified DC. DC coils do not contain a rectifier. When the coil is at rated voltage, the magnet will be silent. At reduced AC voltage, some slight hum may be heard. However the magnet must not chatter.

If for some reason a coil must be changed, proceed as outlined below, referring to Figure 9.

1. De-energize **all** circuits as previously specified.
2. Disconnect the leads to the coil terminals, noting their position for later reconnecting.
3. Disconnect the line and the load leads from the contactor terminals.
4. Remove for ¼" x 20 screws (S) holding the frame subassembly to the mounting base.

Changing Operating Coil (Cont.)

5. Lift the line side of the frame subassembly away from the mounting base until two dowels (D) are clear of their holes. The frame subassembly will automatically move under pressure from the kickout system until the kickout bar reaches the end of its slots in the mounting base. The frame subassembly is then free to be moved outward away from the coil and put elsewhere.
6. The coil is then accessible. Remove the two mounting screws (M) to free the coil.
7. Install replacement coil and replace mounting screws.
8. Place the frame subassembly onto the mounting base so that the two posts extending from the crossbar go through the oblong slots in the base and into the notches in the kickout bar. Push the frame subassembly a short distance along the surface of the mounting plate toward the kickout bar until the dowels (D) slip into the dowel holes. Replace the mounting screws (S). **Make sure that the coil leads to the L63 auxiliary contact are not pinched under the frame feet.**
9. Reconnect coil and recheck contactor for correct adjustment per this leaflet. By hand jiggle the ends of the kickout bar(K) to make sure it is seated onto the posts of the cross bar.
10. Reconnect line and load cables.

Auxiliary Contact Adjustment

The nominal .34" pretravel gap shown for the L63 auxiliary contact (normally-closed) in the left upper portion of Figure 9 is important. If the gap is too big, the "hold" winding of the operator coil will not be inserted as the contactor closes, and the pickup winding will burn out, because the pickup winding is only intermittently rated. If the gap is too small, the hold winding will be inserted too soon, reducing the force to "hold" before the contactor is closed, and producing an oscillation like a doorbell. In a particular contactor, the .34" gap may need slight adjustment to avoid these problems. The key is not the measurement, but the performance of the magnet. Replacement L63 auxiliary contacts are available as Part No. 578D461G03.

The Type J auxiliary contacts are not as critical. In the open position, their plungers may rest lightly against the operating arm, or may have a small clearance.

However, neither plunger should bottom solidly in the closed contactor position, as discussed under **Magnet Operating Range**. If required, the auxiliaries can be adjusted by resetting their mounting brackets in their slotted holes. Adjust the L63 by loosening the two slotted hexagonal washer head screws the hold the L63 mounting bracket, repositioning and tightening. These bracket mounting screws are accessible from the top side of the contactor and are recognized by the slotted holes under their heads.

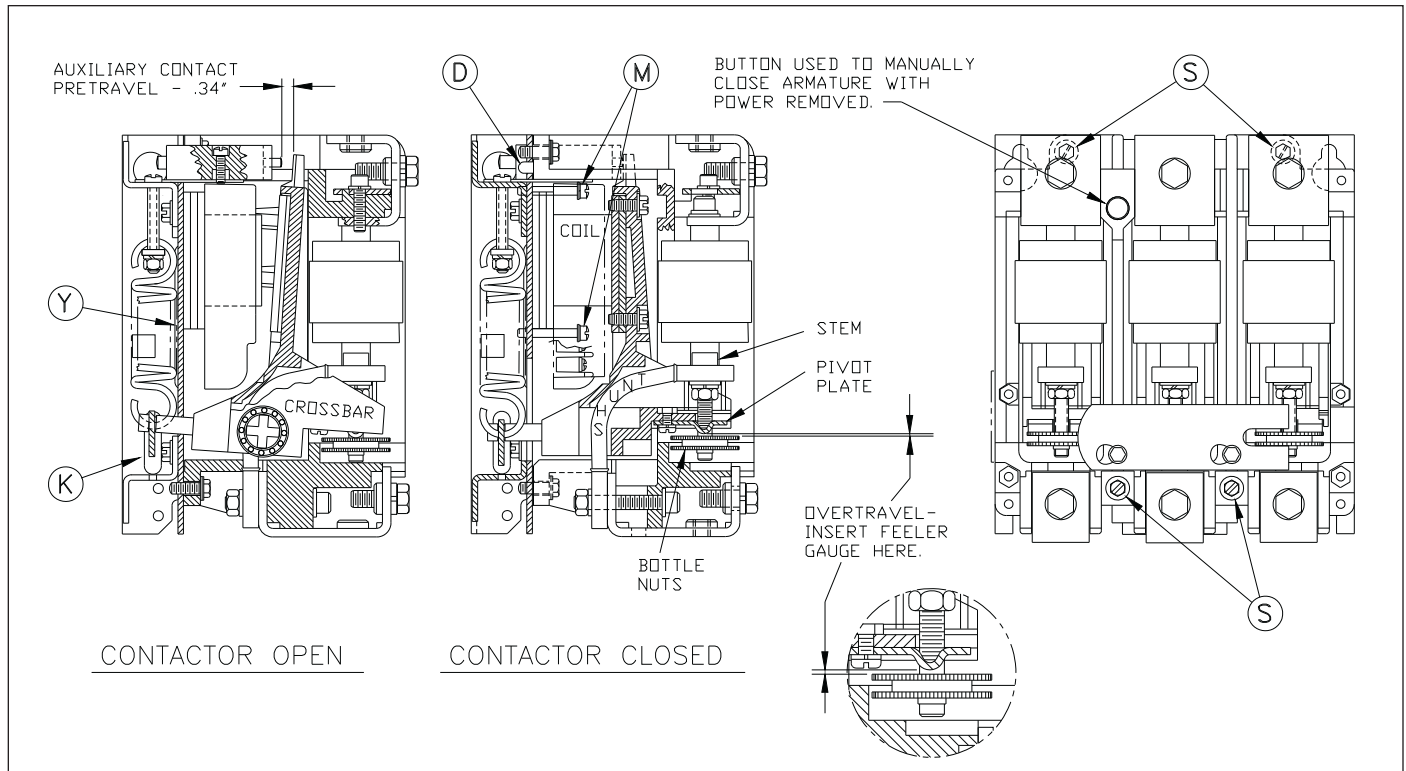

Fig. 9 Contactor Portion of a V200 Motor Controller

Kickout Spring Adjustment

The kickout spring is not disturbed by any maintenance described in this leaflet, and it should not need to be adjusted. However, when the contactor is in the de-energized, open position, the crossbar should be solidly against the frame, so that it cannot move any further open even when pulled. It can removed, the kickout spring must be stretched to hold the crossbar firmly against the frame. Refer to figure 10. Loosen the lock nuts and tighten the adjusting screws alternately (to keep the spring on centerline) until the force from the spring holds the crossbar properly open. Lock the two lock nuts again.

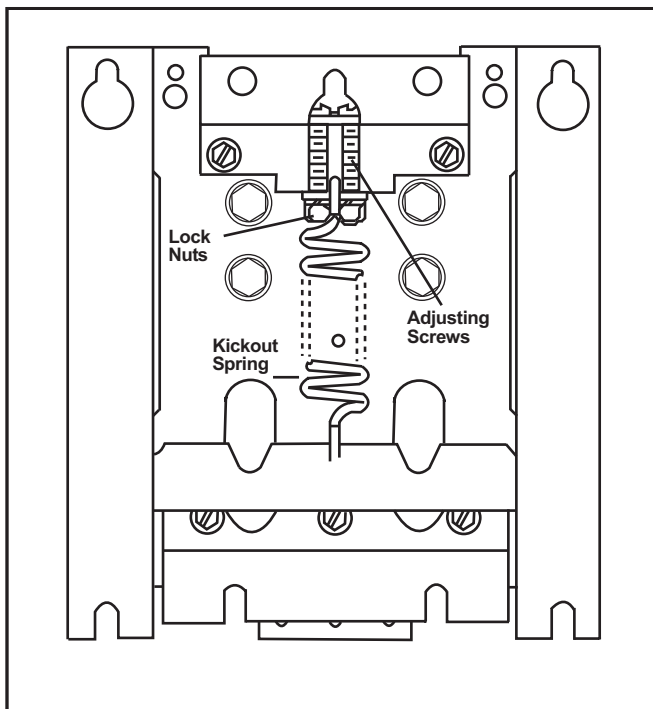

Fig. 10 Kickout Spring

Inspection After Short Circuit

The V200 motor controller is intended to be protected by power fuses and/or a circuit breaker in accordance with the NEC. However, the magnitude of a short circuit may exceed the damage threshold of the vacuum bottles. After a short circuit, the unit should be examined for any apparent physical damage, or deformation

of conductor bars and cables. If there is any evidence of severe stress, it is recommended that the unit be replaced. If the overtravel has changed significantly (from the last inspection) on one or more bottles, the unit should be replaced.

A dielectric test would not by itself confirm that the unit should be returned to service after a fault. However, if there is no physical evidence of stress, and if the overtravel exceeds the .020 in. minimum, the bottles can then be dielectrically tested as outlined previously. If physical stress, overtravel, and dielectric are O.K., it is reasonable to return the unit to service after a fault.

Insulation Level

Refer to the insulation resistance measurements between poles and from each pole to ground that were recorded at start-up and subsequent intervals. Measure the same points in the same manner and record. Investigate any sudden reduction in resistance or any unusually low reading.

Dust and moisture are detrimental to electrical equipment. Industrial equipment is designed to tolerate a less-than-perfect environment. However, excessive dust can cause trouble, and should be wiped or blown off at appropriate intervals. If the contactor is wet for any reason, it must be dried until insulation resistance between poles and from each pole to ground has returned to normal.

TABLE VIII - ACCESSORIES

Fuse Block Kits - Meet requirements of NEC concerning common control fusing

Order Cat No.	Qty.	Description
F56	2	Contactors mounted Fuse Holder for 1 600 volt Bussman KTK Fuse
FKR	1	Panel mounted Fuse Holder for 2 Class CC (Bussman KTKR) Fuses*

*Use when available fault current exceeds 10,000 amperes

Order Fuses Separately By Ampere Rating.

Controller Size	Minimum Wire Size in Control Circuit	Suggested Fuse Size †
5 or T	#16 AWG	10 AMP

† When using a control transformer, select fuse size per the National Electrical Code.